

Magnom™ Blue 20

TECHNICAL SPECIFICATIONS

Part Number	
Standard Flux Plates	IL 128 21 S U 1 1/2" BSP
Stainless Steel Flux Plates	IL 128 21 S U 1 1/2" BSP ST
Standard Flux Plates	IL 128 21 S U 1 1/2" NPT
Stainless Steel Flux Plates	IL 128 21 S U 1 1/2" NPT ST
Mounting Method In-line	
Port Connection 1 1/2" BSPP/ 1 1/2" NPT Female (1 1/4" flow through the core)	
Flow Direction As indicated on housing	
Construction Materials	
Head	Polypropylene (PP)
Bowl	Polypropylene (PP)
Mandrel	Polyvinyl chloride (PVCu)
Flux Plate (Standard)	Mild steel CR4 zinc plated and passivated
Flux Plate (Optional)	Ferritic Stainless Steel 430
Magnet	Ferrite C5/C8
C-Clip	Stainless Steel
O-rings	Viton
Housing Pressure & Temperature Rating	
Max. Operating Pressure	8 barg (115 psig)
Burst Pressure	30 barg (435 psig)
Max. Temperature	50°C (112°F)
Approx. Contaminant Holding Capacity 4 kg (9 lb)	
Fluid Compatibility Compatible with a wide range of coolants, cutting oils.	
Unit Weight 16.9 kg (37 lb 8 oz)	
Optional Extras NPT Adapter in Polypropylene, Plastic-spanner, Floor mounting bracket, Cleaning cabinet, Insulation Jacket.	
Available Spares Body O-ring, Magnom™ core, Bowl, Head.	



FEATURES & BENEFITS

- ◆ This Magnom™ unit has high contaminant holding capacity, which makes it the ideal choice for high contaminant environments.
- ◆ The units are the best low cost alternative to the Process unit and are most suitable in metal working environments.
- ◆ Screw-in bowl makes the Magnom™ core easily accessible for inspection and cleaning without disconnection of pipe work.

APPLICATIONS



Power Generation Automotive Pulp & Paper Industrial Steel/ Heavy Industry Metal Working

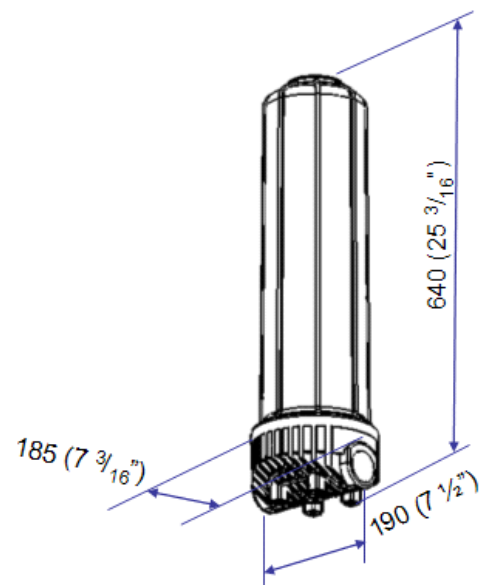

Magnom™

Innovation Centre, Warwick Technology Park, Gallows Hill, Warwick CV34 6UW UK

The company reserves the right to alter specification without prior notice.

© Fluid Conditioning Systems Ltd – 2006; Issue: [EU020520061]

"Magnom", "Magnom The Ferrous Eliminator", "Magnom Clear/ Blue 20" are trademarks or registered trademarks of Fluid Conditioning Systems Ltd

www.magnum.com

sales@magnum.com